

Rozmery v mm
Maße in mm
Dimensions in mm

OVALIS T 03 PLECH-183C

140 kg

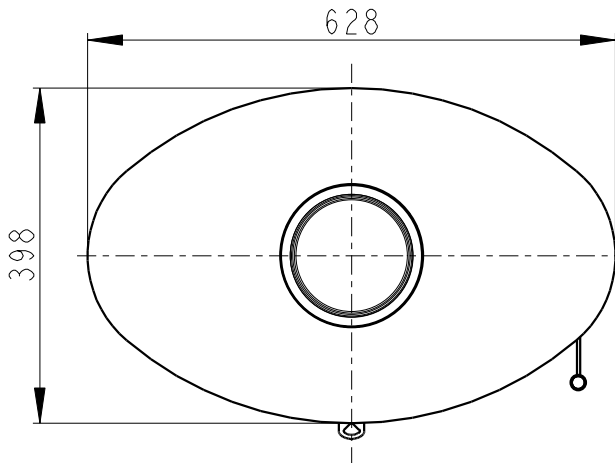
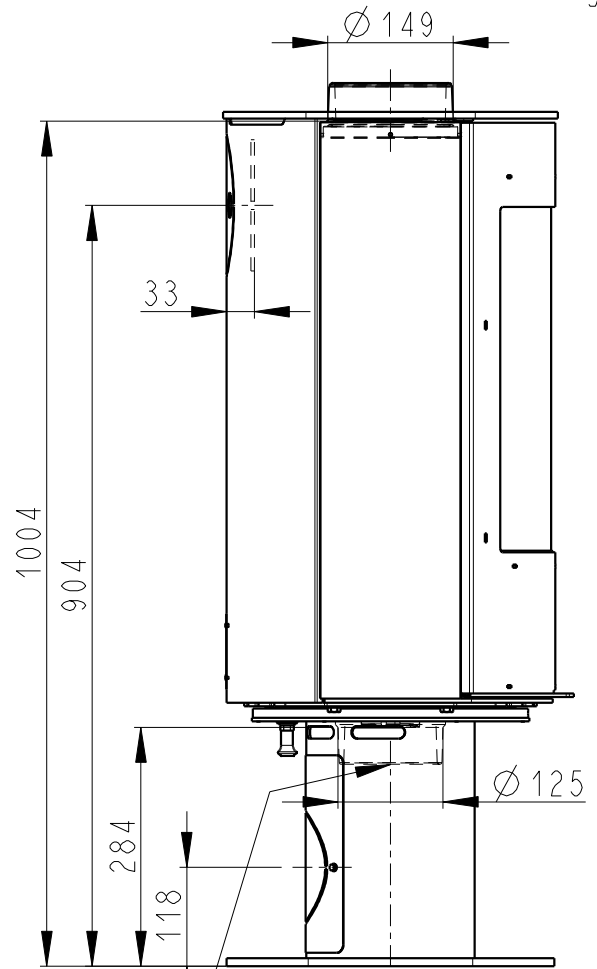
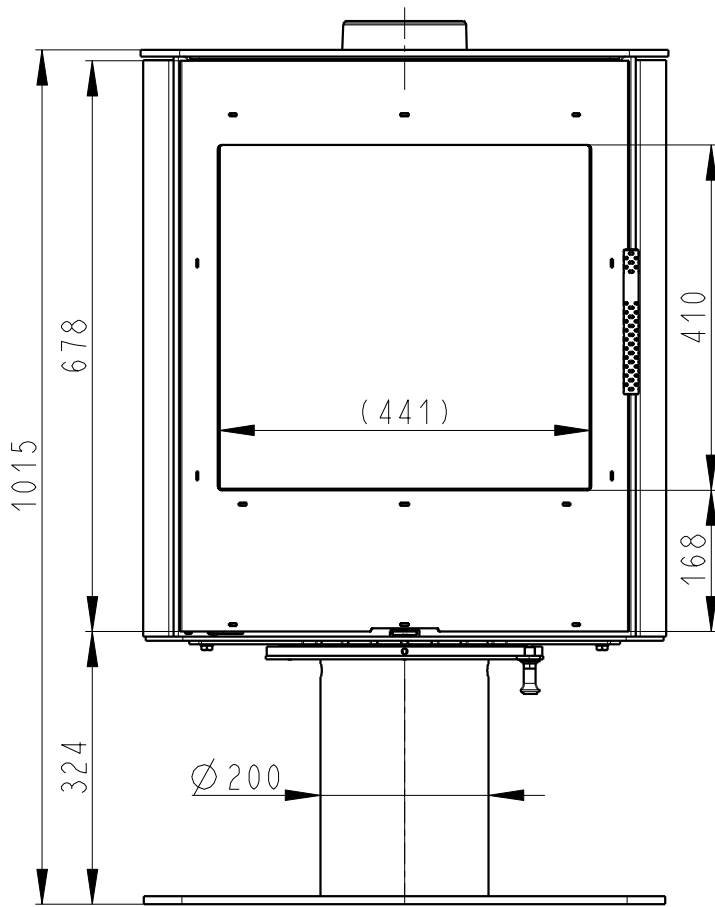

Centralni privod vzduchu Ø 125
Zentral luftzufuhr Ø 125
Central air inlet Ø 125

Primarni a sekundarni vzduch
Primarluft und sekundarluft
Primary air and secondary air

Zajisteni rotace
Rotation sicherung
Rotation lock

